



C E S A R

D E S I G N

S Y S T E M

Edition 09.2018  
EN — IT

The kitchen planning

# MODULARITY

## Modularità

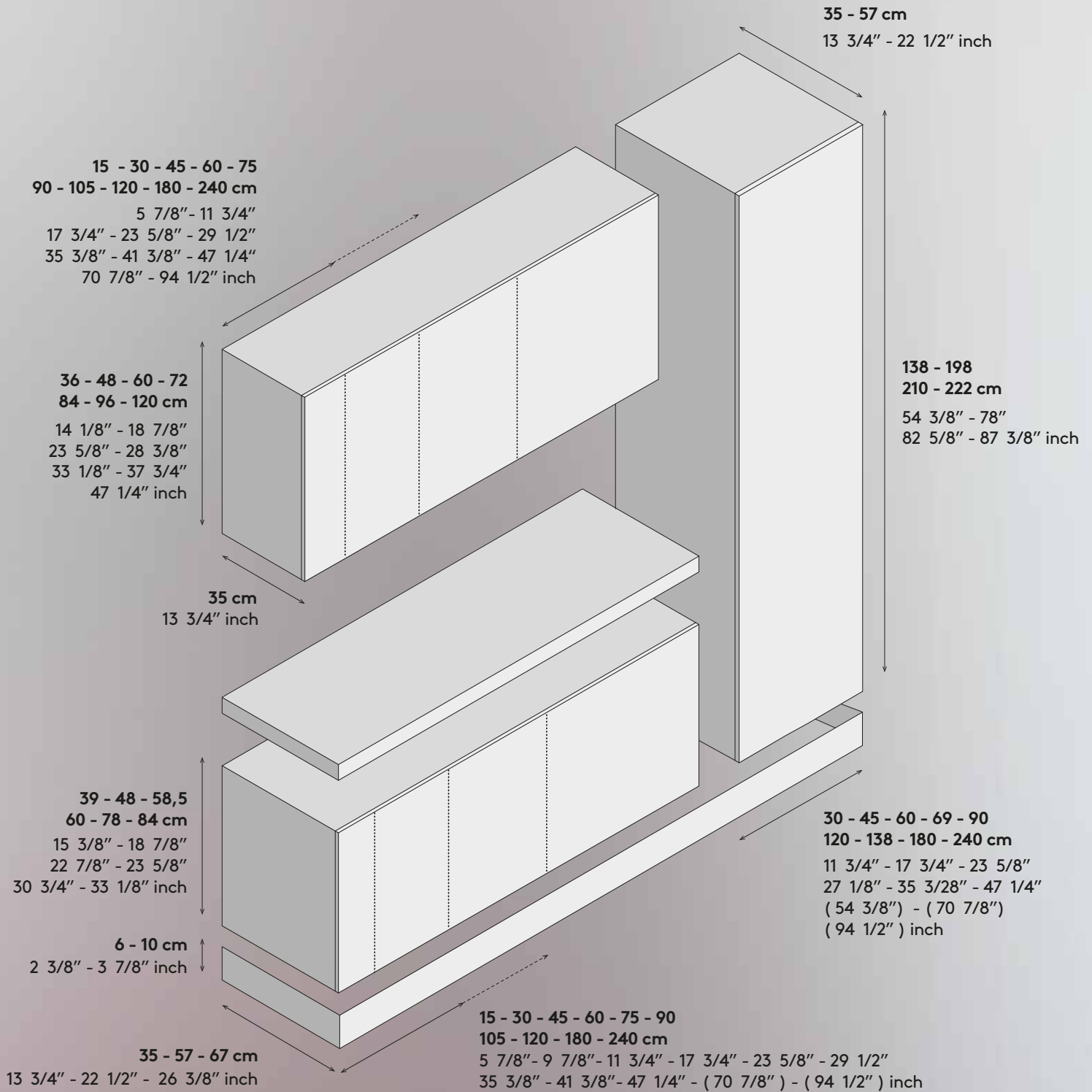

(\*): Please check Cesar price list to look into our design possibilities / Per approfondire le possibilità progettuali di Cesar consultare il listino

# MODULARITY UNIT

## Modularità Unit

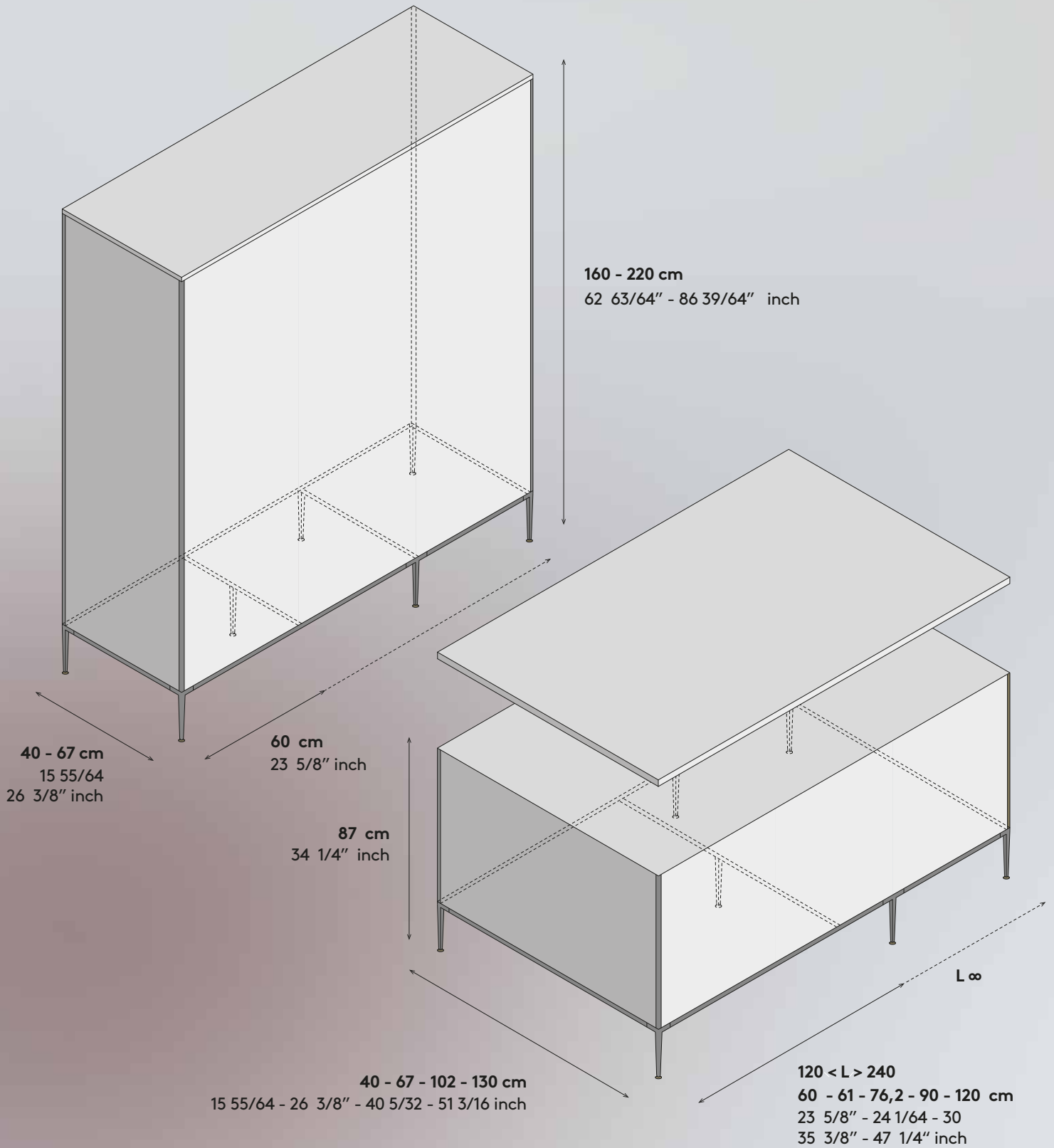

(\*): Please check Cesar price list to look into our design possibilities / Per approfondire le possibilità progettuali di Cesar consultare il listino

## OPENING METHODS

### Aperture

#### GRIP RECESS / Gola

---

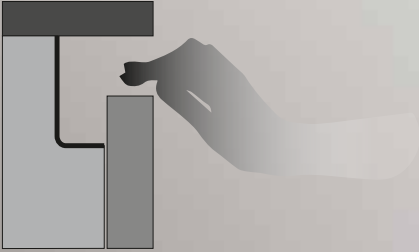

**L - SHAPED GRIP**  
Gola "L"

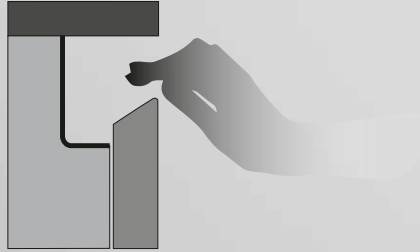

**30° L - SHAPED GRIP**  
Gola "L" 30°

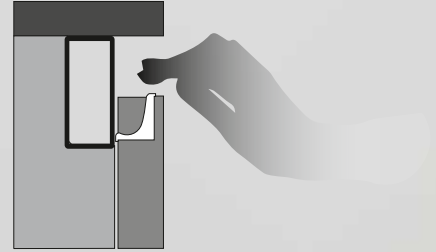

**STRAIGHT GRIP WITH RECESSED HANDLE**  
Gola "dritta" con maniglia ad incasso

#### PUSH - PULL

---

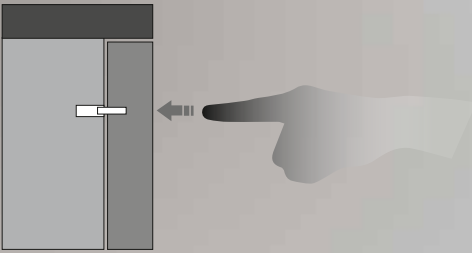

**PUSH PULL**

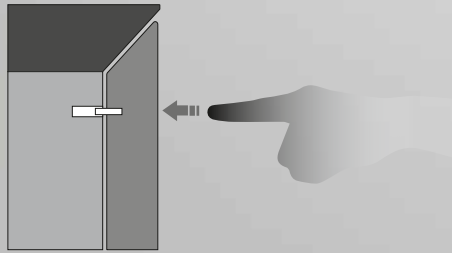

**PUSH PULL 45°**

#### HANDLE / Maniglia

---

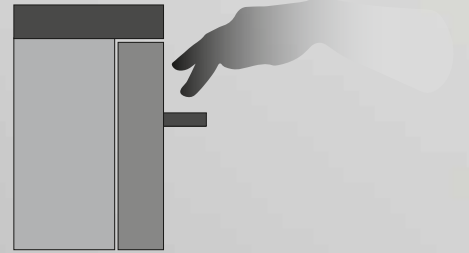

#### GRIP EDGINGS / Presa

---

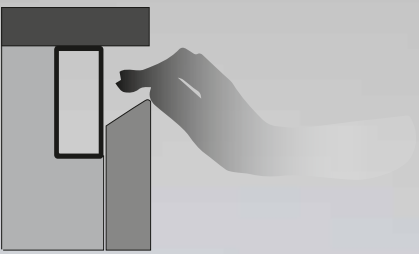

**30° GRIP EDGING**  
Presa 30°

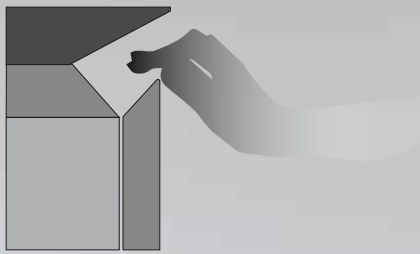

**45° GRIP EDGING**  
Presa 45°

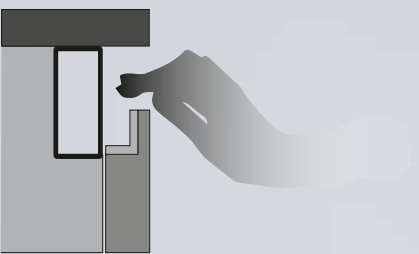

**"FRAME" GRIP EDGING**  
Presa Frame

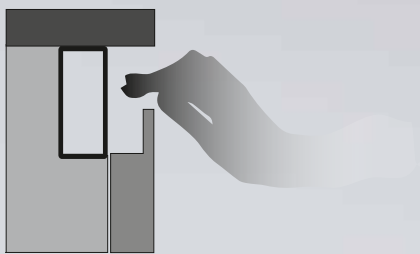

**"STEP" GRIP EDGING**  
Presa Step

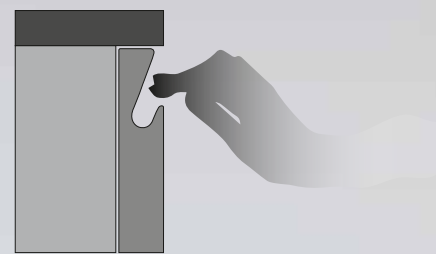

**"INSIDE" GRIP EDGING**  
Presa Inside

# COLLECTIONS

## Collezioni

### UNIT



22 mm  
0 55/64"

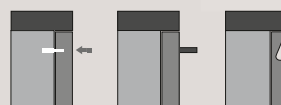

### MAXIMA 2.2



22 mm  
0 55/64"

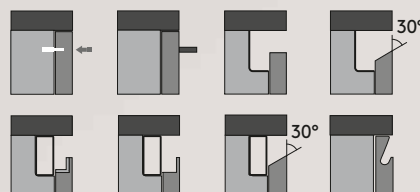

### N\_ELLE



22 mm  
0 55/64"

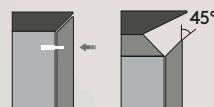

### KALEA



14 mm  
0 35/64"

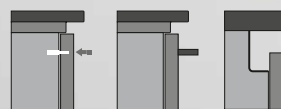

### ARIEL



18 mm  
0 45/64"

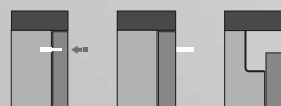

# ERGONOMICS

## Ergonomia

### WORKTOP DEPTH / Profondità top

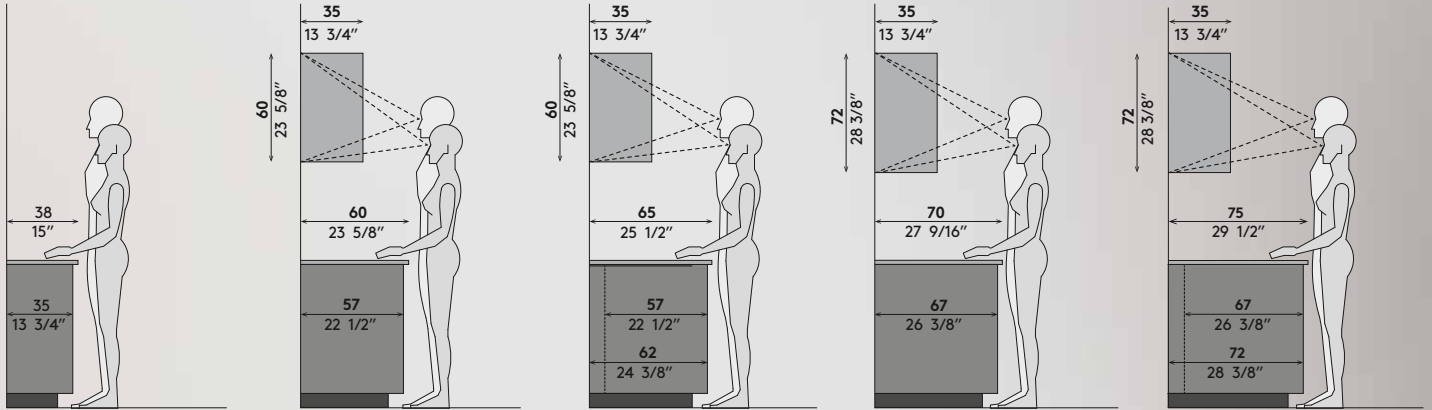

### DEPTH OF BASE UNITS AND DRAWERS / Profondità cassette e basi

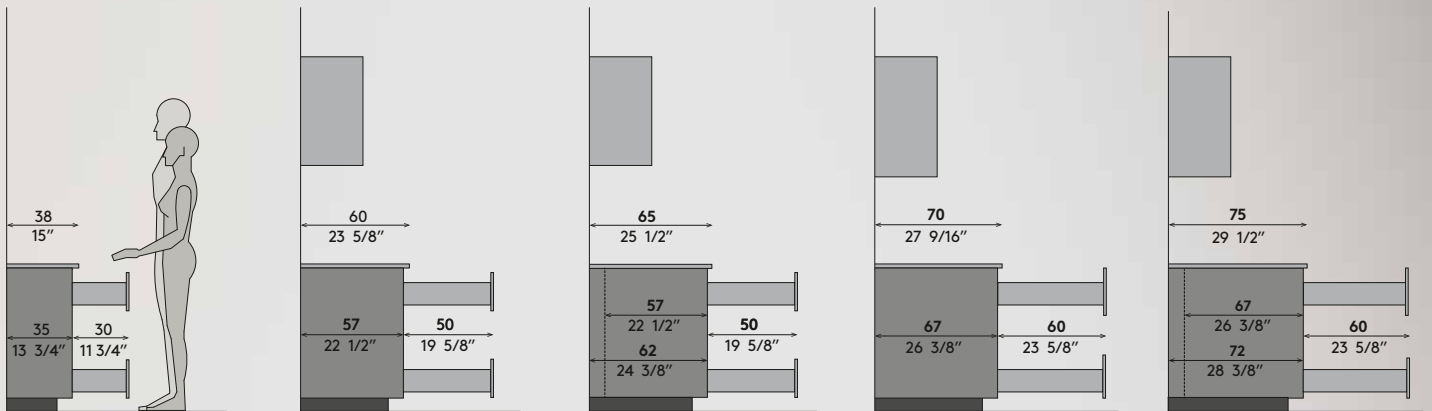

### MINIMUM DISTANCES / Distanze minime

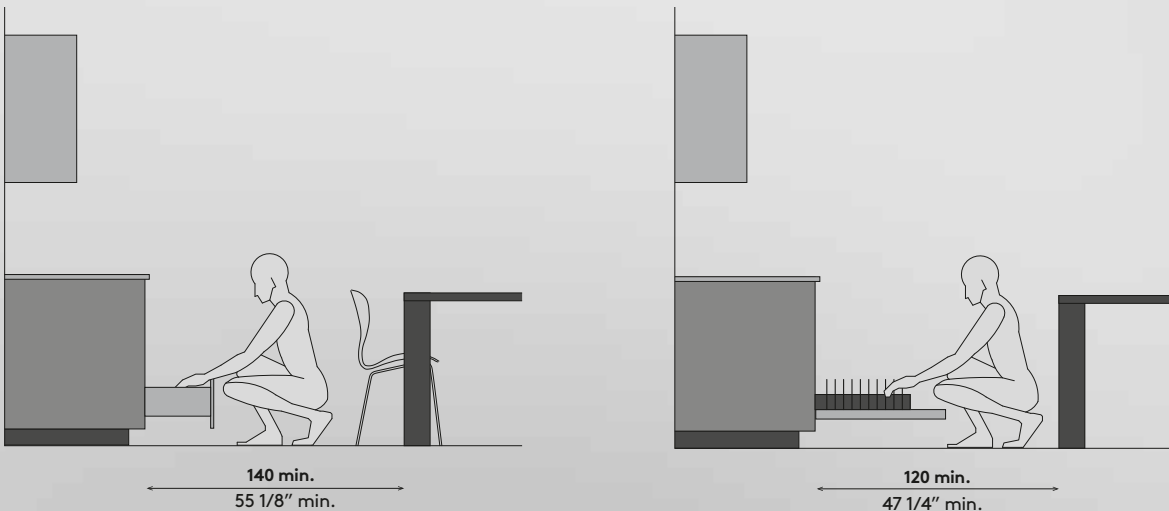

# WORK TRIANGLE

## Triangolo funzionale

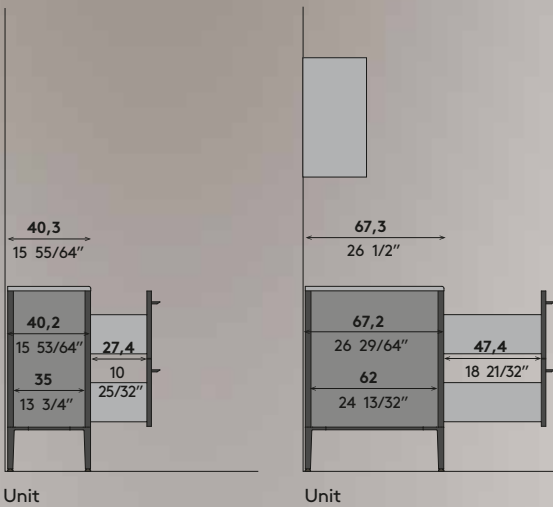
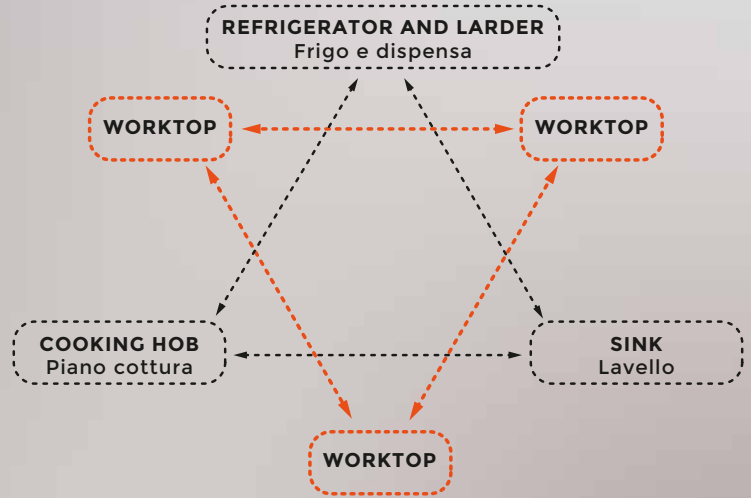
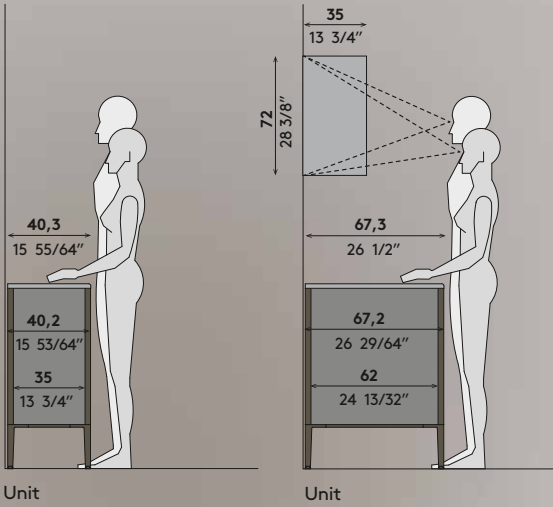

### EXAMPLES / Esempi

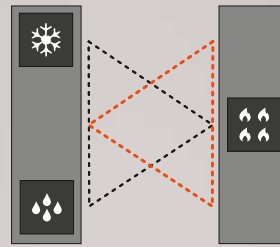

**LINEAR LAYOUT**  
Disposizione lineare

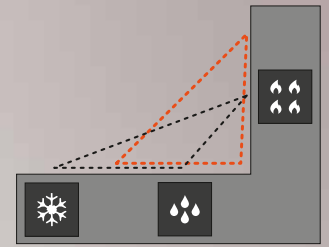

**L-SHAPE LAYOUT**  
Disposizione angolare

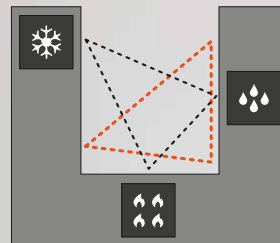

**U-SHAPE LAYOUT**  
Disposizione a "U"



**LEGEND / Legenda**

